

PLAN VIEW

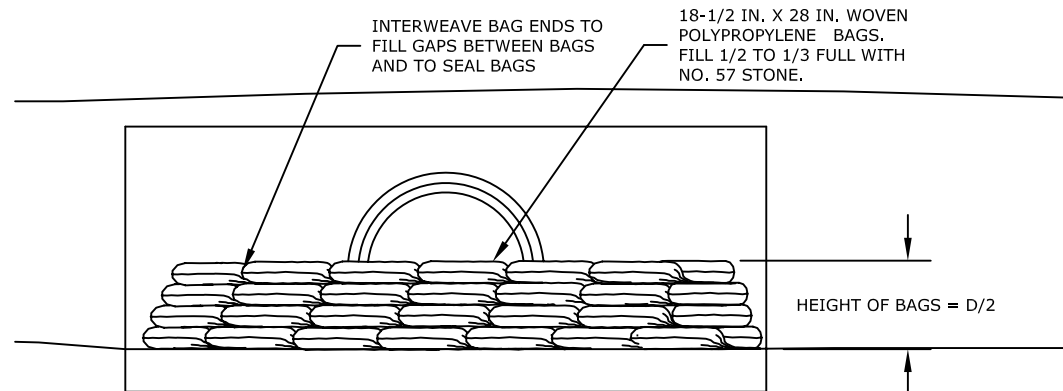

UPSTREAM ELEVATION

Purpose:

Install stone bag protection at all headwall inlets to pool water, providing opportunity for settling sediment before it enters headwall.

Design Criteria:

Bag specifications: Approximately 18 1/2-Inch X 28-Inch woven polypropylene bags.

Stone: Use KTC No. 57 Stone.

Height of stone bags above culvert Inverts: Construct a minimum of two courses of bags.

The stone-filled bags shall be stacked to a height equal to 1/2 the diameter of the culvert being protected.

SOURCE: LOUISVILLE MSD



City of Bowling Green

Public Works Planning and Design
1011 College Street
Bowling Green, Kentucky 42101

**STANDARD HEADWALL
INLET PROTECTION**

STANDARD DRAWING NO. **SMP-11-10**

APPROVED BY: _____ DATE _____
DIRECTOR OF ENGINEERING